

SI(RL)



PRAMET

S

Internal Screw Clamped Threading Holder for TN 11, 16 or 22 Insert

Right/Left hand screw lock boring bar for internal threading with TN11, 16 or 22 ER/EL inserts. Suited for threading in metric or inch profile. Minimum internal diameter Ø13 mm. Also suited for shallow grooving. Available with shank size Ø16 up to Ø40 mm. Body treated for longer tool life.

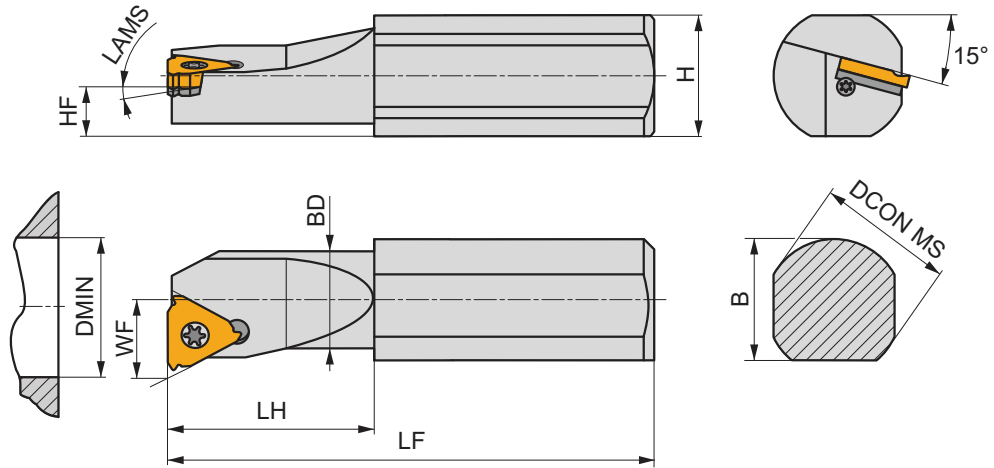
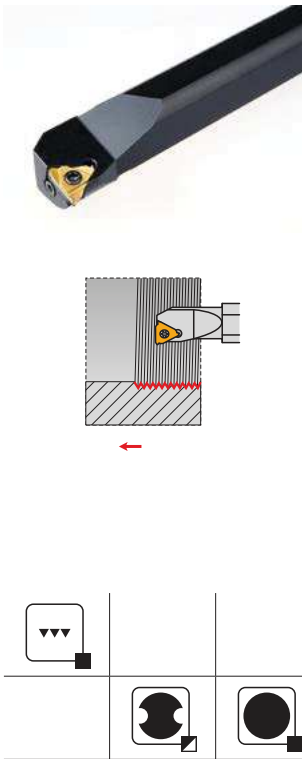

Product	B	DCON MS	DMIN	BD	WF	H	HF	LF	LH	LAMS	[°]	[]	[]
	[mm]	[mm]	[mm]	[mm]	[mm]	[mm]	[mm]	[mm]	[mm]	[]			
SIR 0010 K 11-0	14.5	16	13	10	7.45	14	7	125	25	0	-	GI085	Z11
SIR 0010 K 11-1	14.5	16	13	10	7.45	14	7	125	25	1	-	GI085	Z11
SIR 0013 M 11-0	14.5	16	16	13	9	14	7	150	32	0	-	GI085	Z11
SIR 0013 M 11-1	14.5	16	16	13	9	14	7	150	32	1	-	GI085	Z11
SIR 1416 N 16-0	14	16	22	17	11.4	14.5	7.5	160	-	0	-	GI022	Z9
SIR 1416 N 16-1	14	16	22	17	11.4	14.5	7.5	160	-	1	-	GI022	Z9
SIR 1416 N 16-2	14	16	16.5	15.5	10.6	14.5	7.5	160	40	2	✓	GI022	Z10
SIR 1820 P 16	18.5	20	27	21	13.85	18	9	170	-	-	-	GI022	Z12
SIR 2325 Q 16	23.5	25	29	26	16.55	23	11.5	180	-	-	-	GI022	Z12
SIR 2532 S 16	30	32	36	32	19.75	25	12.5	250	-	-	-	GI022	Z12
SIR 2532 S 22-2	30	32	25	25	16.65	25	12.5	250	80	2	✓	GI076	Z14
SIR 2532 S 22-A	30	32	36	32	21.65	25	12.5	250	-	-	-	GI076	Z13
SIR 3240 T 22-A	38	40	48	40	25.85	32	16	300	-	-	-	GI076	Z13
SIL 0010 K 11-0	14.5	16	13	10	7.45	14	7	125	25	0	-	GI085	Z11
SIL 0010 K 11-1	14.5	16	13	10	7.55	14	7	125	25	1	-	GI085	Z11
SIL 0013 M 11-0	14.5	16	16	13	9	14	7	150	32	0	-	GI085	Z11
SIL 0013 M 11-1	14.5	16	16	13	9	14	7	150	32	1	-	GI085	Z11
SIL 1416 N 16-0	14	16	22	17	11.4	14.5	7.5	160	-	0	-	GI022	Z9
SIL 1416 N 16-1	14	16	22	17	11.4	14.5	7.5	160	-	1	-	GI022	Z9
SIL 1416 N 16-2	14	16	16.5	15.5	10.6	14.5	7.5	160	40	2	✓	GI022	Z10
SIL 1820 P 16	18.5	20	27	21	13.85	18	9	170	-	-	-	GI022	Z12
SIL 2325 Q 16	23.5	25	29	26	16.55	23	11.5	180	-	-	-	GI022	Z12
SIL 2532 S 16	30	32	36	32	19.75	25	12.5	250	-	-	-	GI022	Z12
SIL 2532 S 22-2	30	32	25	25	16.65	25	12.5	250	80	2	✓	GI076	Z14
SIL 2532 S 22-A	30	32	36	32	21.65	25	12.5	250	-	-	-	GI076	Z13
SIL 3240 T 22-A	38	40	48	40	25.85	32	16	300	-	-	-	GI076	Z13